

## Features:

- \* MOV provides spike & surge protection.
- \* Anodized aluminum housing.
- \* Dual Voltage 12 or 24VDC (selectable)
- \* Anti-residual magnetism designed.
- \* Complete mounting hardware included.



## Specifications:

- \* Voltage Tolerance: +/- 15%
- \* Current Draw: 500mA@12Vdc ; 250mA@24Vdc
- \* Operating Temperature: -10~55C (14~131F)
- \* Humidity: 0~95% non-condensing
- \* Locks surface temperature (when the power is on)  
<current temperature +20C
- \* Holding force: upto 500lbs (272kg) dependent on door construction
- \* Dimensions:
  - Magnet: (L)250. (W)42. (D)26mm
  - Armature Plate: (L)185. (W) 38. (D) 12mm
  - Mounting Plate:(L)250. (W)25. (D) 5mm
- \* Special Finishes for Magnet & armature plate: Zinc
- \* Epoxy Potting Compound: E87252(S), UL94V-0
- \* Weight (approx.) 2.0Kg

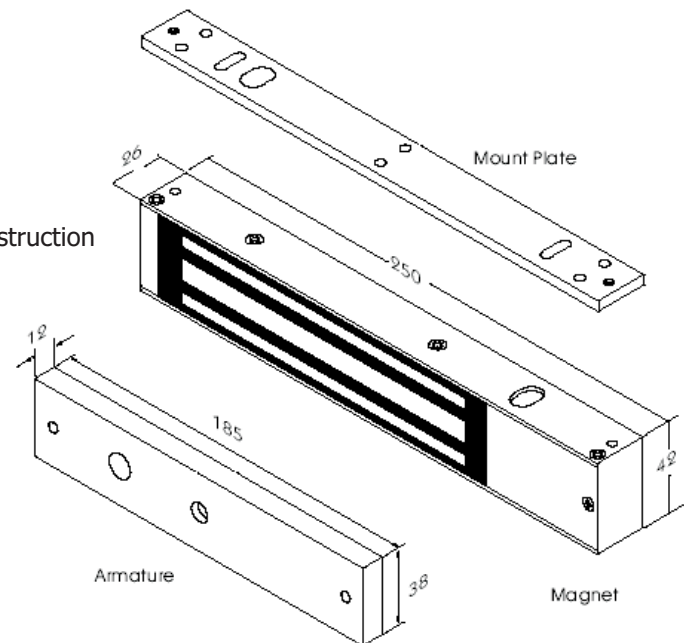

## Warranty:

SPECIALIZED SECURITY PRODUCTS Ltd Equipment are warranted against defects in materials and workmanship while used in normal service for a period of 1 year from the date of sale to the original customer.

## Disclaimer:

The information and specifications printed in this manual are current at the time of publication. The SPECIALIZED SECURITY PRODUCTS Ltd policy is one of continual development and improvement; therefore SPECIALIZED reserves the right to change specifications without notice.

## **SPECIALIZED SECURITY PRODUCTS LTD**

Units 18-20 Park Farm Industrial Estate  
Ermine Street, Buntingford ,Herts SG9 9AZ